



STANDARD



APPLICATIONS

The DTH-XED series is specification grade recessed Edge-Lit LED exit sign with built in battery backup. The XED features an architectural, slim design to fit into any environment. Attractive and functional, this unit is completely self-contained and utilizes reliable, energy-efficient LED illumination.

FEATURES

- * Ultra bright, energy efficient, long life Red LEDs
- * UV-stabilized ultra-clear acrylic edgelit panel provides consistent, uniform illumination
- * Double face utilizes factory installed silver mylar background panel
- * Dual 120/277 voltage
- * Charge rate/power "ON" LED indicator light and push-to-test switch for mandated code compliance testing
- * 4.8V long life, maintenance-free, rechargeable NiCd battery
- * Internal solid-state transfer switch automatically connects the internal battery to LED board for minimum 90-minute emergency illumination
- * Capable of recharging a discharged battery in 24 hours

HOUSING

- * Premium-grade, extruded aluminum housing
- * Cover is easily detachable from below, providing accessibility for service or maintenance.
- * Self-adhesive Chevron appliques and guide template provided for directional indication



WARRANTY / LISTING

- * Five year warranty on all electronics and housing. Battery prorated for two years
- * Meets UL924, NFPA 101 Life Safety Code, NEC, OSHA, Local and State Codes
- * UL Listed for damp locations (68°F – 122°C)
- * Certified to CEC under Title 20 Regulations

DIMENSIONS

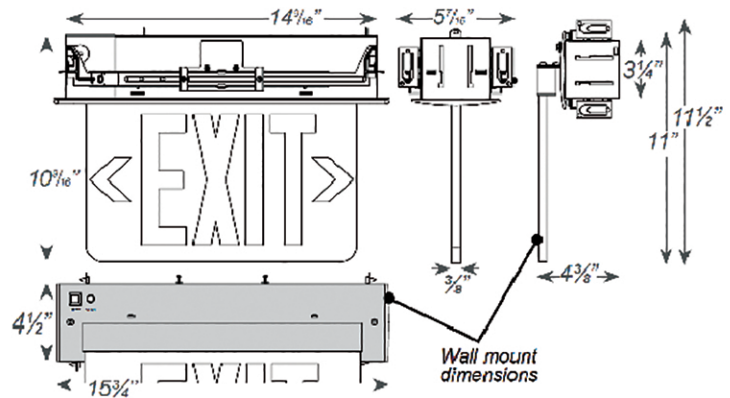

MOUNTING

- * Compatible with drywall or drop ceiling mount installations.
- * Bar hangers included
- * Cut out template included

ORDERING INFORMATION

PART #	No of faces	Letter Color	Panel	Housing Color
DTH-XEDRCA-1	1 Single	Red	C Clear	Aluminum
DTH-XEDRMA-2	2 Double		M Mirror	